

Discover the Brightness

Titanium Dioxide Manufacturing Process

Sulfate Process



Base Material Production

Storage

Storage of ilmenite ore.



Ore Milling

Milling of ilmenite ore and reduction of moisture content.

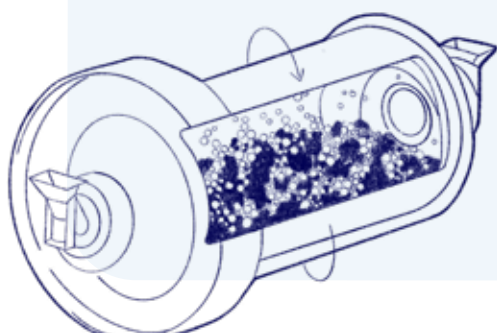

Digestion

Digestion of the ore's mineral components with sulfuric acid and separation of unsolvable components.

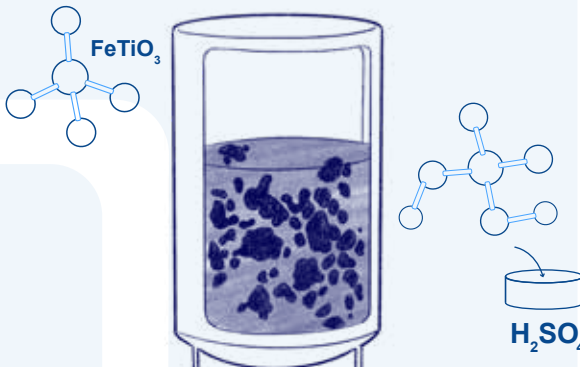

Crystallization

Copperas crystallization and separation.

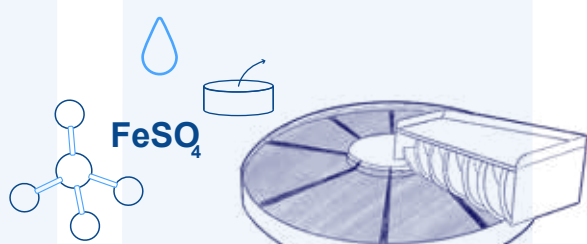

H₂SO₄

Precipitation

Hydrolysis of titanyl sulfate and precipitation of solid titanium oxyhydrate.

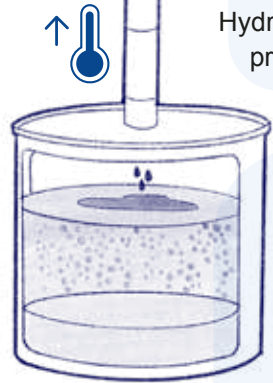

TITANOXYHYDRAT

Purification

Purification of titanium oxyhydrate to remove chromophoric elements.

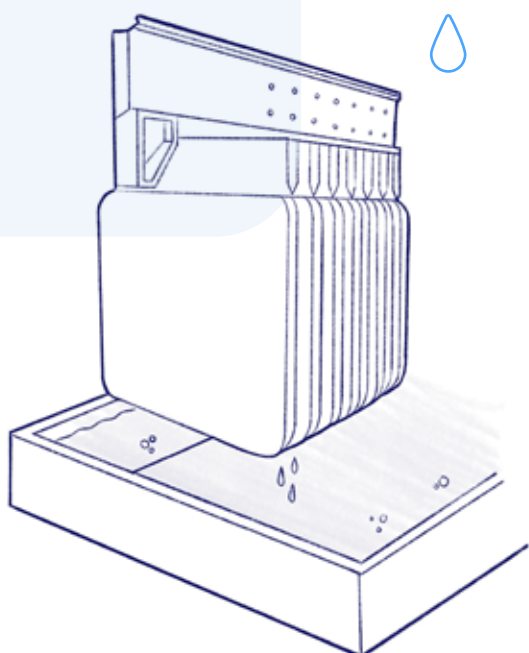

Calcination

Drying and crystalline structure determination of the titanium dioxide.

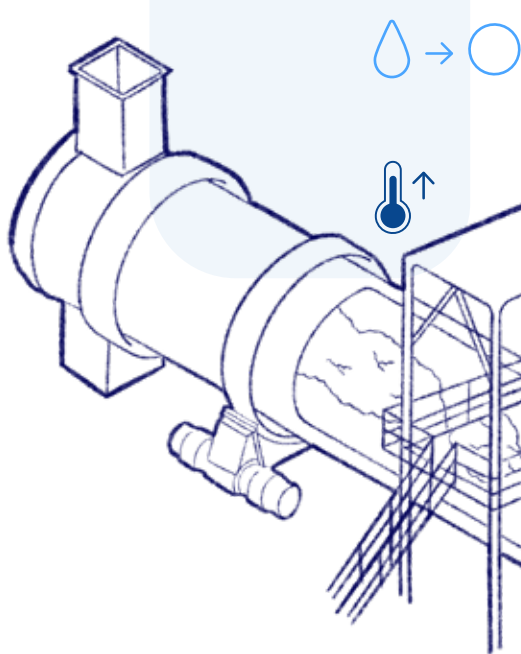

Dry Milling

Milling of the calcined aggregates in order to decrease coarseness.



Finishing

Wet Milling

The TiO₂ is wet milled to reduce the size of any coarse particles and optimize the particle size distribution.

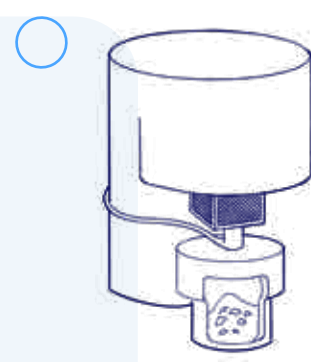

Inorganic Treatment

Treatment compounds are added to determine the final application.

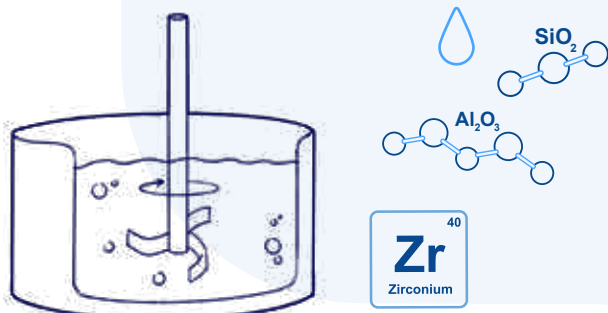

Filtration

The treated suspension is washed and dewatered.

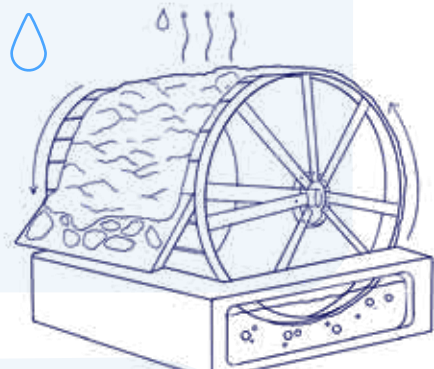

Drying

The remaining moisture content is reduced.

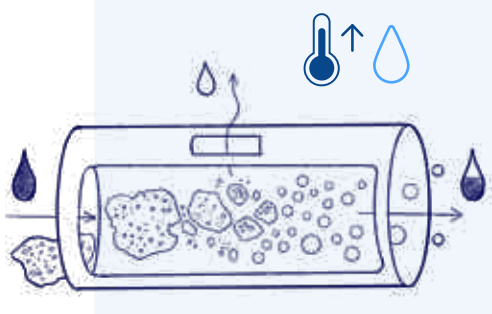

Steam Milling

Further deagglomeration of the dry material to achieve optimal particle size distribution.

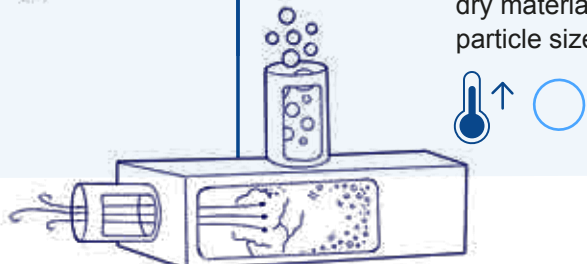

Packaging



Finished Titanium Dioxide

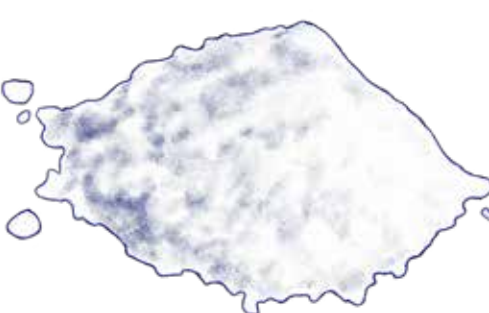

Brighter together

KRONOS